



Item # \_\_\_\_\_

# Model 919E Automatic Gravity Feed Slicer



Automatic Gravity Feed Slicer Model 919E



Model 919E



## Safety and Convenience Features

Berkel Model 919E automatic gravity feed slicer features Berkel's time proven hollow ground stainless steel knife, built-in, dual-action sharpener and a number of safety features. The tapered permanent guard covers the non-slicing portion of the knife even when the sharpener and center plate are removed. The unit is easy to clean and disassembles quickly without tools.

## Accessories

- Stainless steel vegetable chute with pusher
- 4" Extension NSF legs (set of 4)
- Skewers with coring tool
- Slaw tray
- Sharpening kit
- Juice cup
- Receiving tray
- Product fence

## Standard Features

- 1-speed, 1/2 HP, totally enclosed and permanently lubricated knife motor
- 1-speed, automatic carriage produces 50 slices per minute
- Furnished in 115/60/1, 4.5 amp, AC, ETL listed; also available in 1/3 HP, 220/60/1, 2.4 amp, AC, ETL Listed
- Low 12/5 VDC voltage for added operator protection
- Finish is stainless steel and sanitary burnished aluminum; unit disassembles quickly without tools for easy cleaning
- Nominal 12-1/2" (318 mm) diameter, hollow ground, hardened and polished forged stainless steel knife
- The carriage handles food up to 11" (280 mm) wide, by 6" (152 mm) high or 8" (203 mm) diameter
- Rear-mounted, stainless steel meat pusher extends over the length of the product table
- Precise slice adjustment to a thickness of 27/32" (21 mm)
- Ergonomic style handle for ease of use
- Built-in, top-mounted, two stone knife sharpener with single lever, dual-action system
- Permanent, tapered knife ring guard covers non-slicing portion of knife even when the sharpener and center plate are removed
- Q-P-Q nickel plated transport slide rod with reservoir wick for reduced wear
- On/off, 3-position, moisture protected switch with power light
- Attached 6-foot, flexible, 3-wire cord and plug for grounded receptacle
- No-Volt release prevents activation of the slicer in the event of a power interruption; operator must restart the slicer

## Options

- 1/3 HP, 220/60/1, 2.4 amp, AC, ETL listed

Approved By: _____ Date _____
----------------------------------

Berkel Company • 4406 Technology Drive • South Bend, IN 46628-9700

**Berkel Miami Inc.-15915 N.W. 57 Avenue-Miami FL, 33014**

**Tel. # 305-622-8899--Fax # 305-622-8803--www.berkelmiami.com**

**Berkel**

# Model 919E

## Automatic Gravity Feed Slicer

Model No.	Cutting Capacity	Slice Thickness	Knife Diameter	Slicing Speed	Product Dimensions		
					Width A	Depth B	Height C
919E	11" (280 mm) wide 6" (152 mm) high 8" (203 mm) dia.	to 27/32" (21 mm)	12-1/2" (318 mm)	50 SPM	20" (508 mm)	29" (737 mm)	24" (610 mm)

Motor	Electrical	Weight	Box Dimensions		
			Width	Depth	Height
1-speed 1/2 HP	115/60/1	Net 114 lbs. (52 kg) Ship 152 lbs. (69 kg)	32" (813 mm)	30" (762 mm)	30" (762 mm)

### Specifications

**Motor:** 1-speed, 1/2 HP, totally enclosed, permanently lubricated ball bearings, thermally protected.

**Carriage:** 1-speed, automatic carriage produces 50 slices per minute.

**Electrical:** Furnished in 115/60/1, 4.5 amp, AC, ETL listed. Also available in 1/3 HP, 220/60/1, 2.4 amp, AC, ETL Listed. Low 12/5 VDC circuitry for added operator protection.

**Finish/construction:** All food contact areas are stainless steel including the pusher, gauge plate, product table, center plate and knife; sanitary burnished aluminum ring guard and one-piece base with non-slip feet. Slicer disassembles quickly without tools for easy cleaning.

**Knife:** Nominal 12-1/2" (318 mm) diameter, hollow ground, hardened and polished forged stainless steel.

**Cutting Capacity:** Carriage handles food up to 11" (280 mm) wide by 6" (152 mm) high or 8" (203 mm) diameter.

**Slice Thickness:** Precision gear system with eccentric gear to prevent backlash, provides infinite slice adjustment and consistent cuts of hard or soft foods from tissue thin to 27/32" (21 mm).

**Full Gravity Feed:** Full 45° angle feed requires less mechanical pressure. Equipped with a rear-mounted, stainless steel meat pusher that runs the entire length of the product table to hold product and minimize waste. An optional screw-in weight is also available. Ergonomic style handle for ease of use.

**Knife Sharpener:** Built-in, top-mounted, two stone, single lever, dual-action system for a lasting, razor-sharp edge. Unit is removable and submersible for easy cleaning.

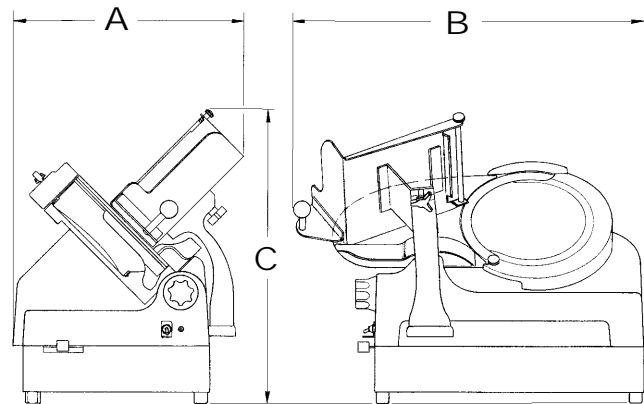

**Knife Ring Guard:** Permanent, tapered knife guard covers non-slicing portion of knife edge even when the sharpener and center plate are removed.

**No-Volt Release:** Prevents activation of the slicer in the event of a power interruption; operator must restart the slicer.

**On/Off Switch:** Highly reliable, moisture resistant, on/off switch and power light.

**Q-P-Q Nickel Plated Transport Slide Rod with Reservoir Wick:** E-nickel plated rod undergoes Q-P-Q impregnation increasing the lubricity of the stainless steel reducing wear properties of the rod & bushings.

**Cord and Plug:** Attached 6-foot, flexible, 3-wire cord and plug for grounded receptacle.

**Warranty:** All parts, service and travel coverage for one year, excluding wear items.

As we continually strive to improve our products, specifications are necessarily subject to change without notice.

Berkel Company • 4406 Technology Drive • South Bend, IN 46628-9700

**Berkel Miami Inc.-15915 N.W. 57 Avenue-Miami FL, 33014**

**Tel. # 305-622-8899--Fax # 305-622-8803--www.berkelmiami.com**

Automatic Gravity Feed Slicer Model 919E

**Berkel**